

KR-35H-V₂ Rough Terrain Crane (Power Jib)

SPECIFICATION

Crane Specification

Crane Performance

Rated Lifting Capacity	9.60m Boom	35.0 Tonne @ 3.0m	(10 Parts of Line)
	16.25m Boom	22.5 Tonne @ 4.0m	(6 Parts of Line)
	22.90m Boom	15.5 Tonne @ 5.0m	(6 Parts of Line)
	29.55m Boom	10.0 Tonne @ 7.0m	(4 Parts of Line)
	36.20m Boom	7.0 Tonne @ 8.0m	(4 Parts of Line)
	8.0m Jib	3.4 Tonne @ 78°	(1 Part of Line)
	13.20m Jib	2.2 Tonne @ 77°	(1 Part of Line)
	Rooster Sheave	4.0 Tonne	(1 Part of Line)
Boom Length	9.6m - 36.2m		
Jib Length	8.0m - 13.2m		
Maximum Lifting Height Above Ground	37.1m (Boom)		
	50.9m (Jib)		
Line Speed (Main)	118m/min (4th layer)		
Line Speed (Auxiliary)	107m/min (3rd layer)		
Hook Speed (Main)	(Parts of Line 10) 11.8m/min (4th layer)		
Hook Speed (Auxiliary)	(Parts of Line 1) 107m/min (2nd layer)		
Boom Derricking Range	0° ~ 83°		
Boom Raising Speed	0° ~ 83°/58 sec		
Boom Extension Speed	9.6m ~ 36.2m/115 sec		
Slewing Speed	2.5 rpm		
Rear Slewing Radius	3,240 mm		

Crane Equipment and Structure

Hoist Equipment	Group 2 Single Winch, 2-Stage Speed Reduction Type Hydraulic Motor Drive / Spur Gear Reducer / Automatic Brake Type (with Foot Brake, Freefall Device), Flow Regulator with Pressure Compensator		
Slewing Equipment	Free Lock Change Switch with Hydraulic Motor Drive / Planetary Gear Speed Reducer (Negative Brake Embedded)		
Slew Circle	Ball Bearing Type		
Boom Derricking Equipment	Direct Press Hydraulic Cylinder Type, Flow Regulator with Pressure Compensator		
Boom Extension Equipment	Hydraulic Cylinder (2) with Wire Rope		
Outrigger Equipment	Type	Fully Hydraulic H Type (Float, Vertical Cylinder Model)	
	Extension Range	6,800 mm (Full Extension)	
		6,200 mm (Intermediate Extension)	
		5,300 mm (Intermediate Extension)	
3,900 mm (Intermediate Extension)			
	2,340 mm (Full Retraction)		
Wire Rope	Main	SeS(48) + 6 × WS(31) ø 16 mm × 195m	
	Auxiliary	IWRC 6 × Fi(29) ø 16 mm × 105m	

Hydraulic Equipment

Oil Pump	Double High Pressure Variable Plunger Type, Gear + Plunger Type
Hydraulic Motor	Hoisting and Slewing: Axial Plunger Type
Control Valve	Multiple Auto Recovery Type (with Pressure Compensator, Flow Regulator)
Cylinder	Double Acting Type
Oil Reservoir	525L

Safety Equipment

ACS (with Overload Protector/Voice Alarm Device), Slewing Automatic Stop Device, Boom Derricking and Boom Extension Stop Device, Swing Clearance Restriction Device, Outrigger Extension Range Auto Detection Unit, Boom Freefall Prevention Device, Overhoist Prevention Device, Drum Lock Device, Drum Hold Safety Device, Automatic Brake Device, Hoist Jam Prevention Device, Hydraulic Safety Valve, Outrigger Lock Device, Slewing Warning Light, Hyd. Fluid Overheat Alarm Device, Operating Oil Filter Clog Warning Device



Kato SS-350SP-V KR-35H-V₂ Rough Terrain Crane (Power Jib)

SPECIFICATION Crane Specification

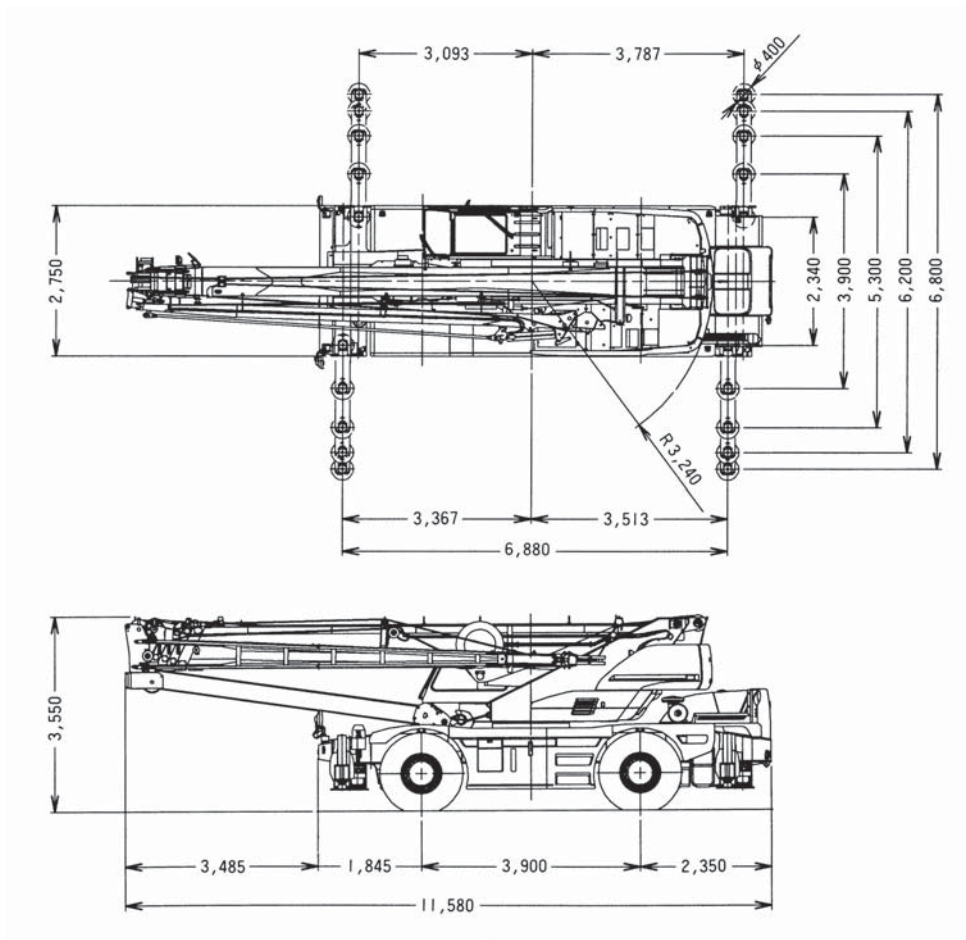

(measurement: mm)

Standard Equipment

- Hydraulic Dehumidifying Air Conditioner
- AM/FM Radio Cassette Deck with Clock
- Drum Revolution Indication Device
- Intermittent Roof Wiper (with Washer)

Optional Components

- Winch Check Camera
- ACS Outside Display Area Display Equipment
- Loud Speaker
- Door Visor



Kato SS-350SP-V KR-35H-V₂ Rough Terrain Crane (Power Jib)

SPECIFICATION

Carrier Specification

Driving Performance

Maximum Travelling Speed	49 km/hr
Uphill Ability	0.60 (tan θ)
Minimum Turning Radius	8.4m (2 Wheel Steering)
	5.3m (4 Wheel Steering)

Weight and Dimensions

Overall Length	11,580 mm approx.
Overall Width	2,750 mm approx.
Overall Height	3,550 mm approx.
Distance Between Axles	3,900 mm approx.
Treads	Front 2,230 mm
	Rear 2,230 mm
Seats	1
Gross Vehicle Weight	
Overall Weight	32,595 kg approx.
Front Axle Weight	16,260 kg approx.
Rear Axle Weight	16,335 kg approx.

Engine

Engine Model	Mitsubishi 6D24-TE I (with Turbo)
Engine Type	6 Cylinder, Water Cooled 4 Cycle, Direct Injection Type Diesel Engine
Total Emission	11.945L
Maximum Power	290ps/2,200 rpm
Maximum Torque	100kg-m/1,400 rpm

Carrier Components and Structure

Drive System	Full-Time 4 Wheel Drive (4x4)
Torque Converter	3 Components, 1 Stage (with Automatic Lock Up Clutch)
Transmission Type	Automatic and Manual Gear Transmission Type (with transfer differential)
Number of Gears	6 Forward Gears, 2 Reverse Gears
Axle Type	Front and Rear: Full Floating Type
Fuel Tank Capacity	300L
Main Brake	Dual System Combined Hydraulic Pneumatic Type, 4 Wheel Disc Brakes (Double Calliper)
Park Brake	Mechanical Type, Transmission Braking Internal Expansion Type
Auxiliary Brake	Exhaust Brake (torque lock-up simultaneous control system through the electric controls), Auxiliary Braking Device for Operation
Suspension Components	Front Hydro-Pneumatic Suspension (with Hydraulic Lock Cylinder Type)
	Rear Hydro-Pneumatic Suspension (with Hydraulic Lock Cylinder Type)
Steering Type	Complete Hydraulic Type Power Steering with Opposite Steering Correction Device
Steering Mode	Front 2 Wheels, Crab Counter, Independent Front/Rear Wheels (5 Modes), (with Rear Steering Automatic Lock Mechanism)
Tyre Size	Front 445/95 R25 177E ROAD
	Rear 445/95 R25 177E ROAD

Safety Components

Emergency Steering Device, Rear Wheel Steering Lock Device, Miss-shift Prevention Device, Brake Fluid Leakage Alarm Device, Suspension Lock Device, Auxiliary Braking Device for Operation, Overrun Alarm Device, Electrically Housable Side Mirrors, Mirror Right Side of the Boom (with Heater), Radiator Fluid Level Alarm Device, Operating Oil Filter Clog Warning Device

Optional Devices

Rear Check Camera, Boom Left Hand Side Check Mirrors

Rated Lifting Capacity Table (1)

9.6m ~ 36.2m Boom										
Working Radius (m)	Outriggers Fully Extended (6.8m) - 360° Full Range					Outriggers Intermediately Extended (6.2m) - Over Side				
	9.6m Boom	16.25m Boom	22.9m Boom	29.55m Boom	36.2m Boom	9.6m Boom	16.25m Boom	22.9m Boom	29.55m Boom	36.2m Boom
3.0	35.00	22.50	15.50	10.00		35.00	22.50	15.50	10.00	
3.5	30.60	22.50	15.50	10.00	7.00	30.60	22.50	15.50	10.00	7.00
4.0	27.50	22.50	15.50	10.00	7.00	27.50	22.50	15.50	10.00	7.00
4.5	24.70	20.70	15.50	10.00	7.00	24.70	20.70	15.50	10.00	7.00
5.0	22.50	19.30	15.50	10.00	7.00	22.50	19.30	15.50	10.00	7.00
5.5	20.60	17.90	14.40	10.00	7.00	20.60	17.90	14.40	10.00	7.00
6.0	19.10	16.80	13.45	10.00	7.00	19.10	16.80	13.45	10.00	7.00
6.5	16.70	15.80	12.55	10.00	7.00	16.70	15.80	12.55	10.00	7.00
7.0	13.00	14.90	11.85	10.00	7.00	13.00	14.90	11.85	10.00	7.00
8.0		13.10	10.60	9.00	7.00		12.40	10.60	9.00	7.00
9.0		11.20	9.60	8.05	6.40		9.70	9.60	8.05	6.40
10.0		9.45	8.60	7.25	5.80		7.90	8.60	7.25	5.80
11.0		7.80	7.80	6.60	5.30		6.40	7.30	6.60	5.30
12.0		6.50	7.05	6.05	4.90		5.30	6.15	6.05	4.90
13.0		5.50	6.30	5.55	4.50		4.40	5.20	5.55	4.50
14.0			5.45	5.10	4.15			4.50	4.80	4.15
15.0			4.70	4.70	3.85			3.90	4.30	3.85
16.0			4.10	4.35	3.60			3.35	3.80	3.60
17.0			3.60	4.05	3.35			2.90	3.35	3.35
18.0			3.10	3.60	3.15			2.45	2.95	3.10
19.0			2.70	3.15	2.95			2.10	2.55	2.75
20.0			2.30	2.80	2.75			1.75	2.25	2.45
22.0				2.15	2.40				1.65	1.95
24.0				1.60	1.85				1.20	1.45
26.0				1.20	1.45				0.80	1.05
28.0					1.05					0.70
30.0					0.75					0.45
32.0					0.50					
33.0					0.40					
Critical Boom Angle	-	-	-	-	-	-	-	-	-	20°
Standard Hook	35t	22.5t				35t	22.5t			
Hook Weight	290 kg	220 kg				290 kg	220 kg			
Parts of Line	10	6	6	4	4	10	6	6	4	4

(unit: metric ton)

Rated Lifting Capacity Table (1)

9.6m ~ 36.2m Boom										
Working Radius (m)	Outriggers Intermediately Extended (5.3m) - Over Side					Outriggers Intermediately Extended (3.9m) - Over Side				
	9.6m Boom	16.25m Boom	22.9m Boom	29.55m Boom	36.2m Boom	9.6m Boom	16.25m Boom	22.9m Boom	29.55m Boom	36.2m Boom
3.0	35.00	22.50	15.50	10.00		35.00	22.50	15.50	10.00	
3.5	30.60	22.50	15.50	10.00	7.00	30.00	22.50	15.50	10.00	7.00
4.0	27.50	22.50	15.50	10.00	7.00	22.20	20.60	15.50	10.00	7.00
4.5	24.70	20.70	15.50	10.00	7.00	17.40	16.60	15.50	10.00	7.00
5.0	22.50	19.30	15.50	10.00	7.00	14.15	13.40	13.90	10.00	7.00
5.5	20.60	17.90	14.40	10.00	7.00	11.80	11.10	12.00	10.00	7.00
6.0	17.50	16.65	13.45	10.00	7.00	10.00	9.35	10.30	10.00	7.00
6.5	14.90	14.05	12.55	10.00	7.00	8.60	8.00	8.90	9.00	7.00
7.0	12.85	12.10	11.85	10.00	7.00	7.50	6.90	7.75	8.10	7.00
8.0		9.25	10.00	9.00	7.00		5.25	6.00	6.50	6.65
9.0		7.25	8.10	8.05	6.40		4.05	4.80	5.25	5.50
10.0		5.85	6.65	6.95	5.80		3.15	3.85	4.30	4.55
11.0		4.75	5.50	6.00	5.30		2.45	3.15	3.55	3.80
12.0		3.90	4.65	5.10	4.90		1.75	2.55	2.95	3.20
13.0		3.20	3.90	4.35	4.50		1.20	2.10	2.50	2.70
14.0			3.35	3.75	3.90			1.60	2.10	2.30
15.0			2.85	3.25	3.45			1.20	1.70	1.95
16.0			2.40	2.80	3.05			0.85	1.35	1.60
17.0			1.95	2.45	2.65			0.55	1.00	1.30
18.0			1.60	2.10	2.35				0.75	1.00
19.0			1.25	1.75	2.00				0.50	0.75
20.0			1.00	1.45	1.70					
22.0				0.95	1.20					
24.0				0.55	0.80					
26.0					0.50					
28.0										
30.0										
32.0										
33.0										
Critical Boom Angle	-	-	-	20°	35°	-	-	25°	43°	53°
Standard Hook	35t	22.5t				35t	22.5t			
Hook Weight	290 kg	220 kg				290 kg	220 kg			
Parts of Line	10	6	6	4	4	10	6	6	4	4

(unit: metric ton)

Rated Lifting Capacity Table (1)

9.6m ~ 36.2m Boom					
Working Radius (m)	Outriggers Completely Retracted (2.34m) (Blocked on Vertical Cylinders) - Over Side				
	9.6m Boom	16.25m Boom	22.9m Boom	29.55m Boom	36.2m Boom
3.0	16.40	14.80	13.90	10.00	
3.5	12.35	11.60	11.40	9.20	7.00
4.0	9.75	9.05	9.50	7.90	7.00
4.5	7.90	7.25	8.00	6.85	6.20
5.0	6.50	5.90	6.75	6.00	5.50
5.5	5.45	4.90	5.70	5.25	5.00
6.0	4.60	4.05	4.80	4.65	4.40
6.5	3.95	3.40	4.15	4.10	3.95
7.0	3.40	2.85	3.55	3.60	3.50
8.0		2.00	2.65	2.85	2.80
9.0		1.20	2.00	2.25	2.25
10.0		0.55	1.40	1.75	1.80
11.0			0.90	1.30	1.40
12.0				0.95	1.05
13.0					
14.0					
15.0					
16.0					
17.0					
18.0					
19.0					
20.0					
22.0					
24.0					
26.0					
28.0					
30.0					
32.0					
33.0					
Critical Boom Angle	-	40°	54°	61°	67°
Standard Hook	35t	22.5t			
Hook Weight	290 kg	220 kg			
Parts of Line	10	6	6	4	4

(unit: metric ton)

Rated Lifting Capacity Table (2)

36.2m Boom + 8.0m Jib						
Outriggers Fully Extended (6.8m) - 360° Full Range						
Boom Angle (°)	5° Offset		25° Offset		45° Offset	
	Working Radius (m)	Load (t)	Working Radius (m)	Load (t)	Working Radius (m)	Load (t)
83.0	5.2	3.40	7.8	2.10	9.9	1.60
78.0	9.5	3.40	11.8	2.10	13.6	1.60
77.0	10.3	3.32	12.6	2.10	14.3	1.60
75.0	11.9	2.96	14.0	1.98	15.8	1.50
70.0	15.7	2.30	17.7	1.66	19.2	1.35
65.0	19.2	1.87	21.0	1.44	22.3	1.21
60.0	22.5	1.58	24.2	1.26	25.2	1.10
56.0	25.0	1.40	26.6	1.14	27.4	1.03
54.0	26.2	1.34	27.8	1.08	28.5	1.00
52.0	27.3	1.12	28.8	1.04	29.5	0.97
50.0	28.3	0.92	29.8	0.85	30.4	0.82
47.0	29.9	0.67	31.2	0.62	31.6	0.62
43.0	31.8	0.40	32.9	0.38		
Critical Boom Angle	40°		40°		45°	
Standard Hook	4.0t					
Hook Weight	60 kg					
Parts of Line	1					

(unit: metric ton)

36.2m Boom + 8.0m Jib						
Outriggers Intermediately Extended (6.2m) - Over Side						
Boom Angle (°)	5° Offset		25° Offset		45° Offset	
	Working Radius (m)	Load (t)	Working Radius (m)	Load (t)	Working Radius (m)	Load (t)
83.0	5.2	3.40	7.8	2.10	9.9	1.60
78.0	9.5	3.40	11.8	2.10	13.6	1.60
77.0	10.3	3.32	12.6	2.10	14.3	1.60
75.0	11.9	2.96	14.0	1.98	15.8	1.50
70.0	15.7	2.30	17.7	1.66	19.2	1.35
65.0	19.2	1.87	21.0	1.44	22.3	1.21
60.0	22.5	1.58	24.2	1.26	25.2	1.10
56.0	25.0	1.20	26.6	1.08	27.4	1.03
52.0	27.3	0.75	28.8	0.70	29.3	0.70
50.0	28.3	0.58	29.8	0.54	30.3	0.54
48.0	29.4	0.42	30.7	0.41	31.2	0.40
Critical Boom Angle	46°		46°		46°	
Standard Hook	4.0t					
Hook Weight	60 kg					
Parts of Line	1					

(unit: metric ton)

Rated Lifting Capacity Table (2)

36.2m Boom + 8.0m Jib						
Outriggers Intermediately Extended (5.3m) - Over Side						
Boom Angle (°)	5° Offset		25° Offset		45° Offset	
	Working Radius (m)	Load (t)	Working Radius (m)	Load (t)	Working Radius (m)	Load (t)
83.0	5.2	3.40	7.8	2.10	9.9	1.60
78.0	9.5	3.40	11.8	2.10	13.6	1.60
77.0	10.3	3.32	12.6	2.10	14.3	1.60
75.0	11.9	2.96	14.0	1.98	15.8	1.50
70.0	15.7	2.30	17.7	1.66	19.2	1.35
65.0	19.2	1.87	21.0	1.44	22.3	1.21
63.0	20.4	1.58	22.4	1.36	23.5	1.16
60.0	22.2	1.13	24.1	1.00	25.1	0.93
55.0	25.1	0.57	26.9	0.48	27.7	0.45
Critical Boom Angle	53°		53°		53°	
Standard Hook	4.0t					
Hook Weight	60 kg					
Parts of Line	1					

(unit: metric ton)

36.2m Boom + 8.0m Jib						
Outriggers Intermediately Extended (3.9m) - Over Side						
Boom Angle (°)	5° Offset		25° Offset		45° Offset	
	Working Radius (m)	Load (t)	Working Radius (m)	Load (t)	Working Radius (m)	Load (t)
83.0	5.2	3.40	7.8	2.10	9.9	1.60
78.0	9.5	3.40	11.8	2.10	13.6	1.60
77.0	10.3	3.32	12.6	2.10	14.3	1.60
74.0	12.7	2.80	14.8	1.90	16.4	1.48
71.0	14.7	2.08	16.9	1.71	18.5	1.38
68.0	16.6	1.44	18.8	1.19	20.3	1.06
Critical Boom Angle	66°		66°		66°	
Standard Hook	4.0t					
Hook Weight	60 kg					
Parts of Line	1					

(unit: metric ton)

Rated Lifting Capacity Table (3)

36.2m Boom + 13.2m Jib						
Outriggers Fully Extended (6.8m) - 360° Full Range						
Boom Angle (°)	5° Offset		25° Offset		45° Offset	
	Working Radius (m)	Load (t)	Working Radius (m)	Load (t)	Working Radius (m)	Load (t)
83.0	6.5	2.20	10.8	1.25	14.2	0.90
78.0	11.3	2.20	15.4	1.25	18.1	0.90
77.0	12.3	2.20	16.2	1.24	18.9	0.86
75.0	14.0	1.99	17.8	1.17	20.3	0.82
70.0	18.2	1.55	21.6	1.02	23.9	0.76
65.0	22.1	1.25	25.3	0.89	27.2	0.70
60.0	25.8	1.04	28.8	0.78	30.2	0.66
55.0	29.3	0.89	32.0	0.69	33.1	0.61
52.0	31.3	0.82	33.7	0.65	34.6	0.59
50.0	32.4	0.72	34.9	0.62	35.6	0.57
47.0	34.1	0.51	36.3	0.45	36.9	0.45
45.0	35.2	0.39	37.2	0.35		
Critical Boom Angle	43°		43°		45°	
Standard Hook	4.0t					
Hook Weight	60 kg					
Parts of Line	1					

(unit: metric ton)

36.2m Boom + 13.2m Jib						
Outriggers Intermediately Extended (6.2m) - Over Side						
Boom Angle (°)	5° Offset		25° Offset		45° Offset	
	Working Radius (m)	Load (t)	Working Radius (m)	Load (t)	Working Radius (m)	Load (t)
83.0	6.5	2.20	10.8	1.25	14.2	0.90
78.0	11.3	2.20	15.4	1.25	18.1	0.90
77.0	12.3	2.20	16.2	1.24	18.9	0.86
75.0	14.0	1.99	17.8	1.17	20.3	0.82
70.0	18.2	1.55	21.6	1.02	23.9	0.76
65.0	22.1	1.25	25.3	0.89	27.2	0.70
60.0	25.8	1.04	28.8	0.78	30.2	0.66
55.0	29.3	0.81	31.9	0.69	33.1	0.61
52.0	31.3	0.57	33.5	0.54	34.6	0.52
50.0	32.4	0.43	34.6	0.40	35.6	0.39
Critical Boom Angle	48°		48°		48°	
Standard Hook	4.0t					
Hook Weight	60 kg					
Parts of Line	1					

(unit: metric ton)

Rated Lifting Capacity Table (3)

36.2m Boom + 13.2m Jib						
Outriggers Intermediately Extended (5.3m) - Over Side						
Boom Angle (°)	5° Offset		25° Offset		45° Offset	
	Working Radius (m)	Load (t)	Working Radius (m)	Load (t)	Working Radius (m)	Load (t)
83.0	6.5	2.20	10.8	1.25	14.2	0.90
78.0	11.3	2.20	15.4	1.25	18.1	0.90
77.0	12.3	2.20	16.2	1.24	18.9	0.86
75.0	14.0	1.99	17.8	1.17	20.3	0.82
70.0	18.2	1.55	21.6	1.02	23.9	0.76
65.0	22.1	1.25	25.3	0.89	27.2	0.70
63.0	23.7	1.15	26.7	0.84	28.4	0.69
61.0	25.0	1.00	28.1	0.80	29.7	0.67
56.0	28.2	0.48	31.0	0.40	32.4	0.37
Critical Boom Angle	54°		54°		54°	
Standard Hook	4.0t					
Hook Weight	60 kg					
Parts of Line	1					

(unit: metric ton)

36.2m Boom + 13.2m Jib						
Outriggers Intermediately Extended (3.9m) - Over Side						
Boom Angle (°)	5° Offset		25° Offset		45° Offset	
	Working Radius (m)	Load (t)	Working Radius (m)	Load (t)	Working Radius (m)	Load (t)
83.0	6.5	2.20	10.8	1.25	14.2	0.90
78.0	11.3	2.20	15.4	1.25	18.1	0.90
77.0	12.3	2.20	16.2	1.24	18.9	0.86
75.0	14.0	1.99	17.8	1.17	20.3	0.82
72.0	16.5	1.71	20.1	1.07	22.5	0.78
70.0	18.0	1.46	21.6	1.02	23.9	0.76
68.0	19.5	1.08	23.0	0.85	25.2	0.70
Critical Boom Angle	66°		66°		66°	
Standard Hook	4.0t					
Hook Weight	60 kg					
Parts of Line	1					

(unit: metric ton)

Rated Lifting Capacity Table (4)

Working Radius (m)						
	Stationary on Rubber					
	9.6m Boom		16.25m Boom		22.9m Boom	
	Over Front	360° Full Range	Over Front	360° Full Range	Over Front	360° Full Range
3.0	16.00	8.80	13.00	8.00		
3.5	16.00	8.80	13.00	8.00		
4.0	14.40	7.50	13.00	6.75		
4.5	13.05	6.25	11.80	5.65	8.50	5.35
5.0	11.85	5.15	10.80	4.60	8.50	5.35
5.5	10.80	4.30	9.90	3.70	8.50	4.50
6.0	10.00	3.60	9.10	3.05	8.50	3.80
6.5	8.70	3.00	8.40	2.50	8.50	3.25
7.0	7.50	2.50	7.30	2.00	7.80	2.75
8.0			5.60	1.20	6.25	2.00
9.0			4.40	0.60	5.05	1.40
10.0			3.50		4.15	0.90
11.0			2.75		3.40	
12.0			2.10		2.80	
13.0			1.60		2.30	
14.0					1.90	
15.0					1.50	
16.0					1.20	
17.0					0.90	
18.0					0.65	
Critical Boom Angle	-	-	-	47°	25°	58°
Standard Hook	35t		22.5t			
Hook Weight	290 kg		220 kg			
Parts of Line	10	10	6	6	6	6

(unit: metric ton)

Rated Lifting Capacity Table (4)

Working Radius (m)						
	Pick & Carry (Travelling Speed Maximum 2 km/h)					
	9.6m Boom		16.25m Boom		22.9m Boom	
	Over Front	360° Full Range	Over Front	360° Full Range	Over Front	360° Full Range
3.0	12.00	6.60	10.00	6.00		
3.5	12.00	6.60	10.00	6.00		
4.0	10.80	5.55	10.00	5.05		
4.5	9.75	4.70	9.15	4.20	7.50	4.00
5.0	8.90	4.00	8.35	3.45	7.50	4.00
5.5	8.15	3.35	7.60	2.80	7.50	3.40
6.0	7.30	2.80	6.95	2.30	6.90	2.85
6.5	6.60	2.35	6.10	1.85	6.35	2.40
7.0	5.90	1.90	5.35	1.45	5.85	2.05
8.0			4.10	0.80	4.65	1.40
9.0			3.20		3.75	0.90
10.0			2.55		3.05	
11.0			2.00		2.50	
12.0			1.50		2.05	
13.0			1.10		1.65	
14.0					1.35	
15.0					1.10	
16.0					0.85	
17.0					0.60	
Critical Boom Angle	-	-	-	50°	35°	60°
Standard Hook	35t		22.5t			
Hook Weight	290 kg		220 kg			
Parts of Line	10	10	6	6	6	6

(unit: metric ton)

Notes for the Rated Lifting Capacity Chart

Rated Lifting Capacity Chart (1) (2) When Using Outriggers

1. The rated lifting capacities are the maximum load guaranteed on firm level ground with the crane set horizontal and includes the weight of the hook block and other lifting equipment. The capacities enclosed in bold lines are based on the structural strength of the machine and the other values are based on the stability of the machine.
2. The operating radii as given in the table are the actual values including the deflection of the boom. Therefore operate the crane based on the operating radius.
3. The operating radii shown for jib operations are based on the values obtained when the jib is attached to the 36.2m boom (full extension). When the boom is not fully extended (28.0m) the jib operations should be performed on the basis of boom angle and not on the operating radius.
4. Do not perform jib operations with the outriggers in the minimum extended state.
5. The lifting capacity for the respective operating ranges will differ according to the outrigger extension. In general, operate the crane with the outriggers fully extended for safe operation. If you cannot extend the outriggers fully due to obstacles that cannot be removed, obtain approval from the site manager then check the crane capacity for the respective operating ranges on the rated lifting capacity charts provided.



Outrigger Extension Status	Intermediately Extended (6.2m)	Intermediately Extended (5.3m)	Intermediately Extended (3.9m)	Fully Retracted
Range α°	35	30	20	3

6. When the boom length is 9.6m the rated lifting capacities for the rooster sheave are equivalent to the rated lifting capacity for the boom minus the weight (290 kg) of the 35 ton hook and have a limit of 4,000 kg. When the boom length is above 9.6m and up to 36.2m, the rated lifting capacities for the rooster sheave are equivalent to the rated lifting capacity for the boom minus the weight (220 kg) of the 22.5 ton hook and have a limit of 4,000 kg.
[Rooster sheave hook: 4 ton hook (weight 60 kg), 1 line].
7. When the boom length exceeds specified length operate according to the smaller rated lifting capacity out of the specified length or the boom length one level up.
8. When using the boom with the jib installed the rated lifting capacities are equivalent to the rated lifting capacity of the boom when the outrigger extension within 6.8m, 6.2m or 5.3m minus the weight of 2.2 ton and minus the weight of 3.0 ton when the outrigger extension is 3.9m.
When the jib is installed do not operate the rooster sheave and when the outriggers are in the minimum extended state and the jib is installed, do not operate the boom.

Notes for the Rated Lifting Capacity Chart

Rated Lifting Capacity Chart (1) (2) When Using Outriggers

9. The critical boom angles for each operation status are shown on the rated lifting capacity charts. If the boom angle is lowered to less than the critical boom angle the crane will tip over even without a load.
10. The standard number of parts of line relating to each boom length is shown in the rated lifting capacity charts. When the standard number of parts of line is not used, each wire rope is limited to 37.3kN (3.8tf).
11. When using the jib if the jib offset angle exceeds the specified angle operations should be based on the rated lifting capacity for the jib offset angle that is one larger than the specified angle.
12. In general, free fall is used to lower the hook only. If it is necessary to lower a load by free fall, its weight should be less than 20% of the rated lifting capacity and sudden braking should not be allowed.
13. The rated lifting capacity chart when the outriggers are in the minimum extended state applies to only the crane with the H type outrigger.
14. The rated lifting capacities do not include wind interference. Stop the operation when a peak of wind speed is 10m/sec above.
15. The crane will tip over or be damaged if operated with a load exceeding that specified in the rated lifting capacity chart or not conforming to correct handling. Insurance will not cover any damage that occurs in these situations.

Notes for the Rated Lifting Capacity Chart

Rated Lifting Capacity Chart (3) When Not Using Outriggers

1. The rated lifting capacities are the maximum loads guaranteed on firm level ground with the tyres at the specified pressure and the suspension lock cylinders fully retracted. They include the weight of the hook and the lifting equipment.
The capacities enclosed in bold lines are based on the structural strength of the machine and the other values are based on the stability of the machine.
[Tyre air pressure: 900kPa (9.0 kgf/cm²)]
2. Rated lifting capacities in the front area differ from those for the full working area. Great care should be taken when transferring from over front to over side as there is a danger of overloading.

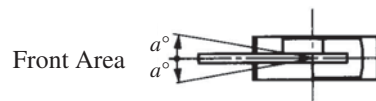

Crane Operation	Stationary Lifting	Mobiling
Range a°	1	1

3. Do not carry out any boom operations, jib operations and free fall operation with the boom length exceeding 22.9m.
4. Apply the parking brake and brake lock when performing stationary lifting.
5. For mobiling place the shift lever in 1st and turn the ultra-low speed switch ON.
6. It is very dangerous for the load to swing while mobiling. Therefore hold the load just off the ground so that it can be lowered onto the ground immediately if you sense any danger and travel at less than 2 km/h. Avoid abrupt acceleration, cornering and braking.
7. Never perform crane operations while mobiling. Also apply the slewing brake.
8. As well as the above items, perform operations according to caution items 2, 6, 7, 9, 10, 14, 15 for when using outriggers.

Working Range Diagram

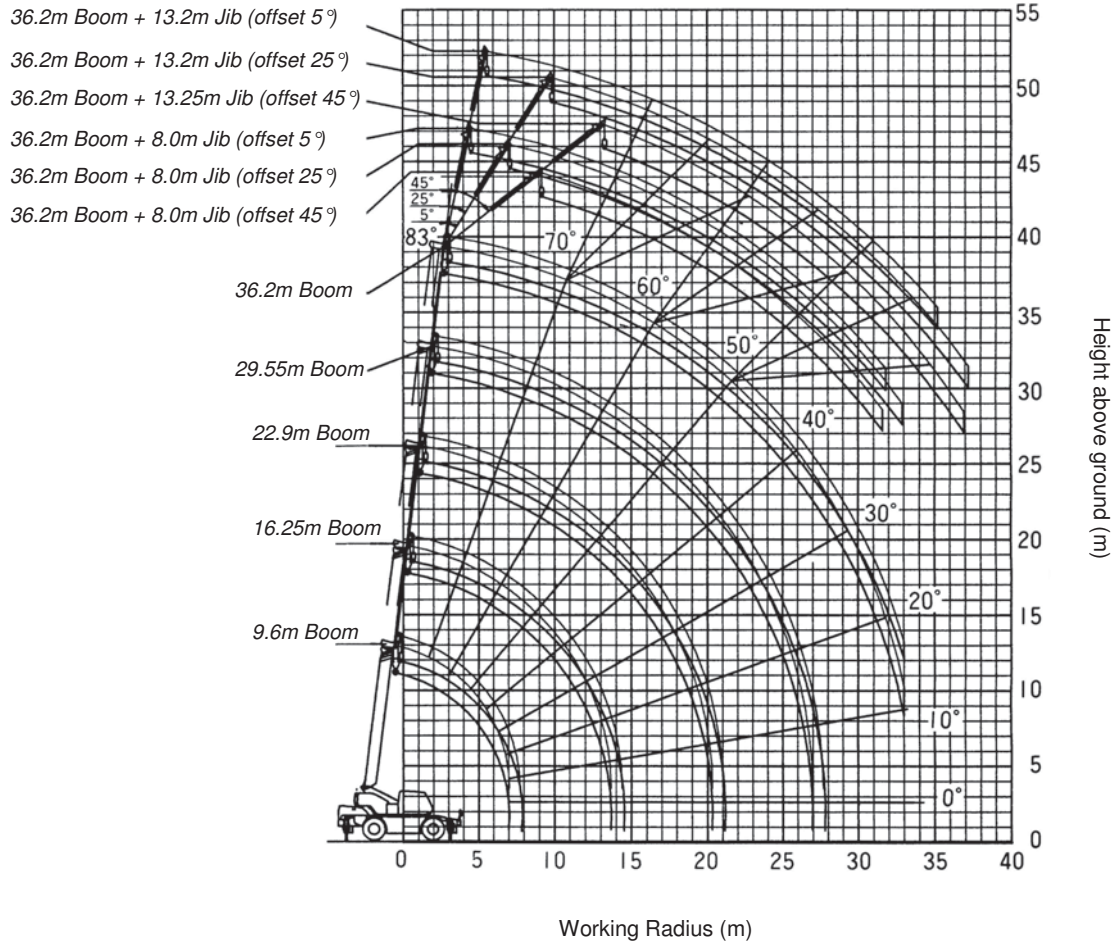

Caution

1. The diagram above does not allow for boom and jib deflections.
2. The chart above is based on operation with all outriggers at full extension.

Minimum Road Width for Right-Angle Turn

Right Turn in 2-Wheel Steering Mode

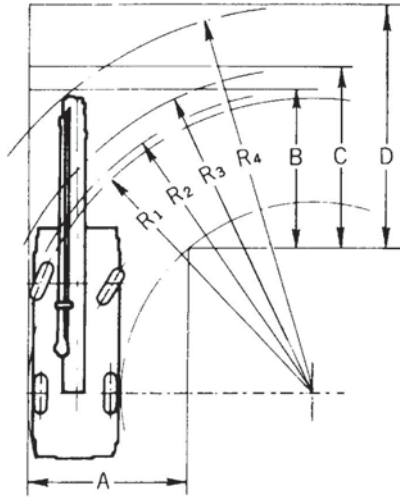

- $R_1 = 8.4\text{m}$
(Minimum Turning Radius)
- $R_2 = 8.62\text{m}$
(Turning Radius of Extremely Outer Tyre)
- $R_3 = 9.52\text{m}$
(Chassis Turning Radius)
- $R_4 = 11.42\text{m}$
(Boom End Turning Radius)
- $A = 4.8\text{m}$ (Width of Entrance)
- $B = 4.8\text{m}$ (Width of Wheel Exit)
- $C = 5.7\text{m}$ (Width of Chassis Exit)
- $D = 7.6\text{m}$ (Width of Exit at End of Boom)

Right Turn in 4-Wheel Steering Mode

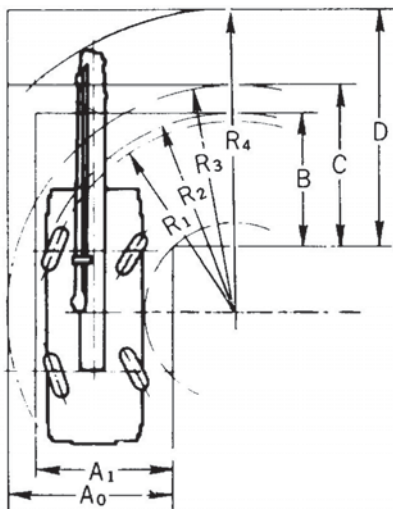

- $R_1 = 5.3\text{m}$
(Minimum Turning Radius)
- $R_2 = 5.5\text{m}$
(Turning Radius of Extremely Outer Tyre)
- $R_3 = 6.47\text{m}$
(Chassis Turning Radius)
- $R_4 = 8.40\text{m}$
(Boom End Turning Radius)
- $A_0 = 4.77\text{m}$ (Width of Entrance)
- $A_1 = 3.80\text{m}$ (Width of Wheel Entrance)
- $B = 3.80\text{m}$ (Width of Wheel Exit)
- $C = 4.77\text{m}$ (Width of Chassis Exit)
- $D = 6.70\text{m}$ (Width of Exit at End of Boom)

Note: The above figures are calculated values

NOTE: Kato Products and Specifications are subject to improvements and changes without notice